

◆ Characteristics / 特點 :

- Small size and easy mounting on a narrow space.
/ 體積小，可安裝在非常狹窄的空間
- Small projected point helps to detect tiny objects with ease.
/ 光點小，可輕易的檢測細小的物體
- Built-in amplifier, supply voltage DC 12 to 24V. To Contol output directly.
/ 供應電源12-24V，內藏放大器，直接控制輸出。
- Transistor output 100mA.
/ 晶體輸出100mA。



◆ Specifications / 規格表 :

Model / 型號	PM6-DU05N	PM6-DU05P
Sensing type / 檢出方式	Diffuse reflection / 擴散反射式	
Sensing distance / 檢出距離	5 cm	
Emitting light / 發光源	Infrared LED 940nm	
Operating voltage / 工作電壓	DC12 ~24V±10% (Ripple P-P : 10% Max.)	
Current Consumption / 消耗電流	20mA Max.	
Load current / 負載電流	100mA Max. at DC24V	
Output type / 輸出模式	NPN L.on	PNP L.on
Protection circuit / 保護電路	Reversed supply circuit protection, short circuit protection output 電源反接保護及輸出短路保護	
Response time / 反應時間	1 ms Max.	
Insulation resistance / 隔離阻抗	20MΩ min. (DC500V)	
Voltage withstandability / 絕緣耐壓	AC1000V 60Hz for 60 Sec.	
Operating temperature / 工作時溫度	-10°C ~ + 45°C (No freezing allowed不可結霜,結冰)	
Ambient humidity / 工作時溼度	35% ~ 85% RH 相對溼度	
Storage temperature / 儲存時溫度	-10°C ~ + 55°C (No freezing allowed不可結霜,結冰)	
Storage humidity / 儲存時溼度	35% ~ 95% RH 相對溼度	
Protection degree / 防水等級	IP64	
Material / 外觀材質	ABS	
Wiring method / 出線方式	Ø2.4 x 2M / 3-wires	
Weight / 重量	Approx.20g	

◆ Dimensions/尺寸圖 :

◆ Wiring diagrams / 接線圖 :

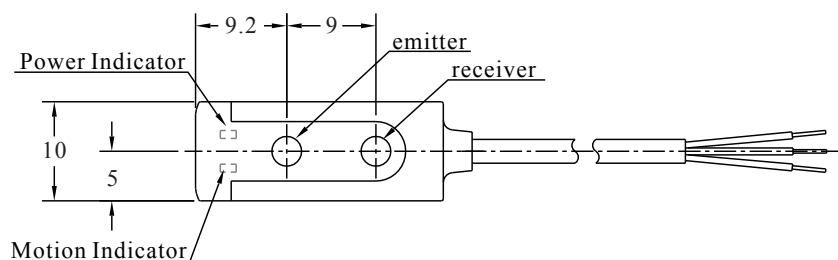
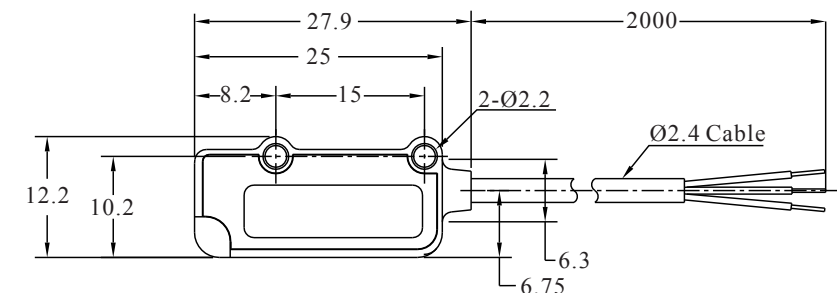

NPN Type

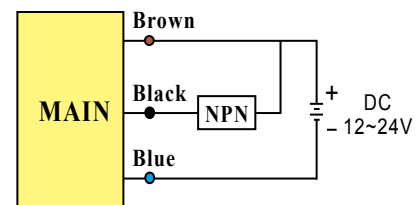

Photo Sensor
Area Sensor
Inductive Proximity Sensor
Capacitive Proximity Sensor
Timer / Counter
Others
Accessories

◆ Characteristics / 特點 :

- Small size but with 50 cm sensing distance, it is very suitable to detect tiny objects.
/ 雖然體積小，但透過距離可到50cm，使它適合於檢測細小的物體
- Built-in amplifier, supply voltage DC 12 to 24V. To Control output directly.
/ 供應電源12-24V，內藏放大器，直接控制輸出。
- Transistor output 100mA.
/ 晶體輸出100mA。



◆ Specifications / 規格表 :

Model / 型號	PM6-T50N	PM6-T50P
Sensing type / 檢出方式	Through beam / 對照式	
Sensing distance / 檢出距離	50cm	
Emitting light / 發光源	Infrared LED 875nm	
Operating voltage / 工作電壓	DC12 ~24V±10% (Ripple P-P : 10% Max)	
Current Consumption / 消耗電流	30mA Max.	
Load current / 負載電流	100mA Max. at DC24V	
Output type / 輸出模式	NPN D.on	PNP D.on
Protection circuit / 保護電路	Reversed supply circuit protection, short circuit protection output 電源反接保護及輸出短路保護	
Response time / 反應時間	1 ms Max.	
Insulation resistance / 隔離阻抗	20MΩ min. (DC500V)	
Voltage withstandability / 絕緣耐壓	AC1000V 60Hz for 60 Sec.	
Operating temperature / 工作時溫度	-10°C ~ +45°C (No freezing allowed不可結霜,結冰)	
Ambient humidity / 工作時溼度	35% ~ 85% RH 相對溼度	
Storage temperature / 儲存時溫度	-10°C ~ +55°C (No freezing allowed不可結霜,結冰)	
Storage humidity / 儲存時溼度	35% ~ 95% RH 相對溼度	
Protection degree / 防水等級	IP64	
Material / 外觀材質	ABS	
Wiring method / 出線方式	Ø2.4 x 2M / 3-wires	
Weight / 重量	Approx.40g	

◆ Dimensions / 尺寸圖 :

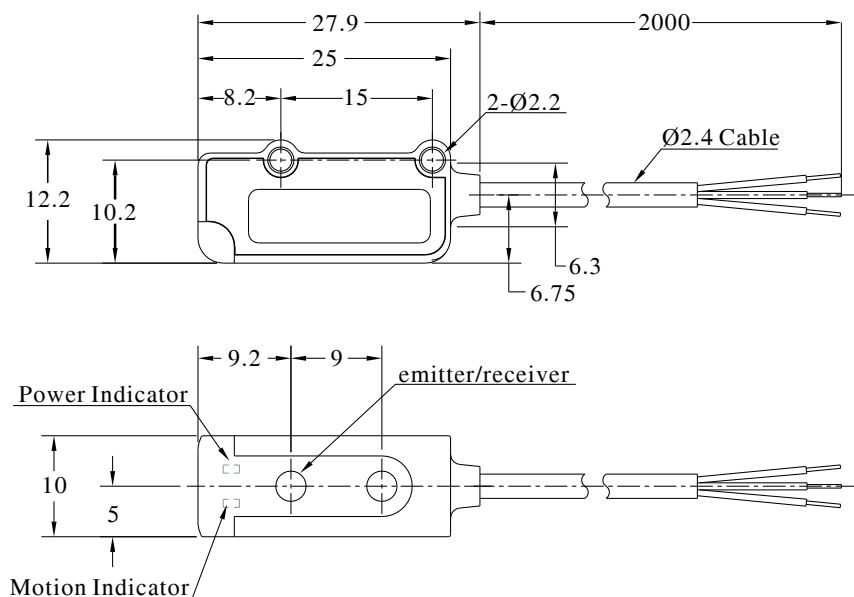

◆ Wiring diagrams / 接線圖 :

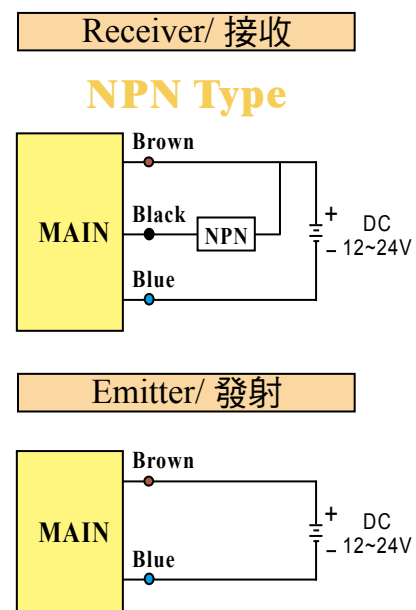

◆ Small size / 體積小

10 mm width only, to enlarge the open space for your operation. / 寬度僅有10mm，讓使用空間更大。

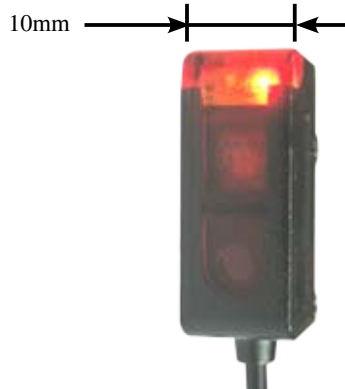

◆ High brightness LED / 高亮度LED燈

It is easy to understand the action situation via high brightness LED. / 讓您在使用的時候，可以很清楚的辨別是否有動作。

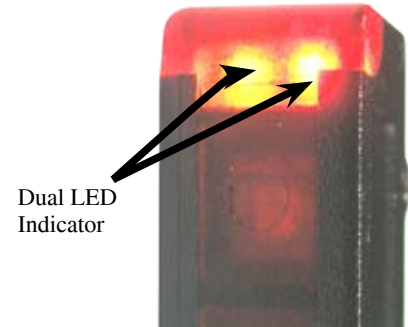

◆ Application / 應用例

- Detecting the passing of products. / 檢測產品通過

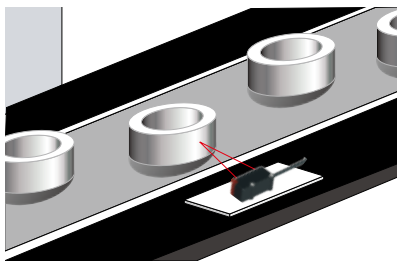

- Detecting the lid on the product is existed or not. / 檢測有無蓋子

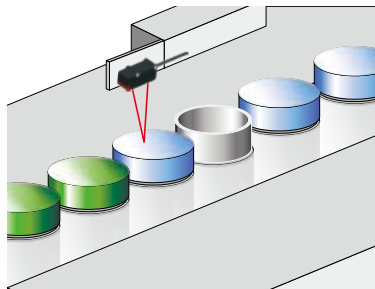

- Detecting metal stamping parts. / 檢測金屬沖壓件

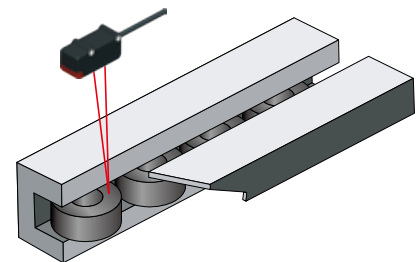

- Detecting envelopes. / 檢測信封

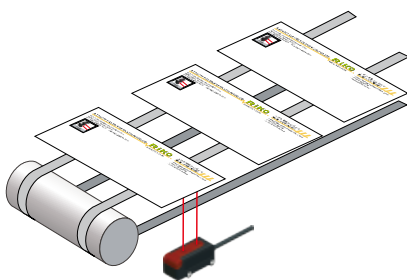

- To detect the steel balls passing inside the glass tube. / 檢測鋼珠通過

