

# Ingress Protection Illumination (IP-65)

## BHP SERIES - Ingress Protection High Intensity Back Light

BHP series is a Ingress Protection Illuminator which LED are arranged in a dense array and shine into a diffuser. The even light shines from the diffuser provides area illumination.

Application: lead frame inspection, shape recognition, size measurement.

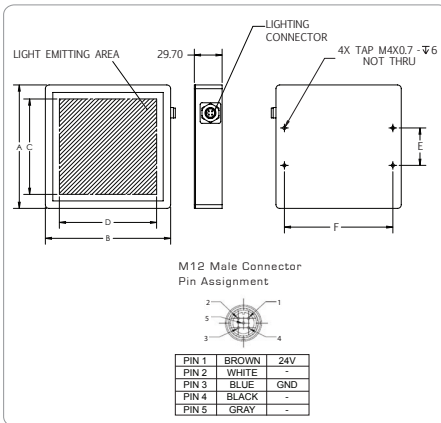
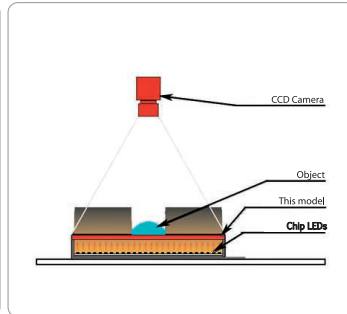
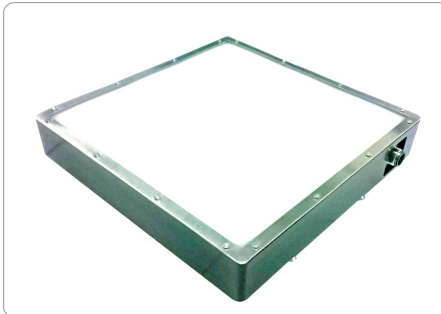

**Technical Specification:**

- Color Red, Green, Blue and White
- 24V DC Input Power
- Continuous and Strobe Applications
- Compact Size
- Lighting Cable 500mm

**Customize Lighting:**

- Customize Sizes, Mounting requirements
- Color and Voltage Available
- Consult Technical Sales for More Information

Model	Dimensions (MM)						Color	Voltage / Watt	Current	Weight (g)
	A	B	C	D	E	F				
BHP1010-X-X	132.0	134.0	102.0	104.0	40.0	116.0	● ● ● ● ● ●	24V / 9.12W	380mA	650
BHP1515-X-X	180.0	180.0	150.0	150.0	75.0	163.0	● ● ● ● ● ●	24V / 6.84W	285mA	1000
BHP1520-X-X	180.0	230.0	150.0	200.0	75.0	213.0	● ● ● ● ● ●	24V / 18.45W	770mA	1200
							● ● ● ● ● ●	24V / 20.16W	840mA	
							● ● ● ● ● ●	24V / 23.04W	960mA	
							● ● ● ● ● ●	24V / 20.16W	840mA	